

QA3

Patient Trolley System

Compact, light weight and manoeuvrable –
the complete solution for patient transport



AneticAid

QA3 PATIENT TROLLEY SYSTEM: Four new models to choose from



QA3
Patient Trolley

QA3
Patient Trolley

Ideal for patient transport, examination and intubation in theatre and clinical areas: supremely manoeuvrable, compact, light weight and robust with maximum patient comfort built in.

Description	Code
QA3 Patient Trolley	21110



QA3
DRIVE
Patient Trolley

QA3 DRIVE
Patient Trolley

Featuring inbuilt motorised drive – operated by innovative touch-sensitive pushing handles: controlled, effortless travel up to gradients of 10°

Description	Code
QA3 DRIVE Patient Trolley	21112



QA3
Patient Trolley

QA3
Powered Patient Trolley

Electrically powered positioning – raise or lower the whole trolley platform, the backrest or raise the middle section to place the trolley into the KneeFlex position – all at the touch of a button.

Description	Code
QA3 Powered Patient Trolley	21116



QA3
DRIVE
Patient Trolley

QA3 DRIVE
Powered Patient Trolley

Top of the range model: combines all features of the Standard, DRIVE and Powered trolleys – the complete answer for moving and positioning patients as easily as possible.

Description	Code
QA3 DRIVE Powered Patient Trolley	21114

Quick reference guide to your QA3 Patient Trolley options:

QA3 Patient Trolley	STANDARD FEATURES
QA3 DRIVE Patient Trolley	STANDARD FEATURES plus INBUILT MOTORISED DRIVE
QA3 Powered Patient Trolley	STANDARD FEATURES plus POWERED FUNCTIONS
QA3 DRIVE Powered Patient Trolley	STANDARD FEATURES plus INBUILT MOTORISED DRIVE and POWERED FUNCTIONS

Specialist Bariatric option of any model available: see page 10

Contents

Standard features	4-5
DRIVE features	6-7
Powered features	8-9
Build Options including Bariatric Trolley	10-11
Accessories	12-13
AnetiCare	14-15



Combining industry knowledge with innovative technology



Designed and produced at our UK manufacturing facility using the latest engineering techniques



Manufacturer, designer and supplier of high quality medical equipment around the world

STANDARD FEATURES

QA3
Patient Trolley

QA3//////DRIVE
Patient Trolley

QA3
Powered Patient Trolley

QA3//////DRIVE
Powered Patient Trolley

Supremely manoeuvrable, compact, light weight and robust with maximum patient comfort built in: ideal for patient transport, examination and intubation in theatre and any other clinical area.

With the backrest raised, it is little more than 1.8m long and it descends lower and is narrower and shorter than nearly all other patient trolleys on the market.

Trendelenburg tilt

extremely smooth and controlled mechanism, even at lowest height



Vertically operated side rails

store away under mattress for a virtually zero transfer gap. Spring counterbalancing allows effortless ease of operation

5th wheel steering

unique mechanism ensures maximum manoeuvrability and easily guided by one person

Patient comfort

exceptional low height capability and store away side rails allow easy mount/dismount particularly for frail and elderly patients. Wide patient platform and pressure care mattress for patient comfort. Optimum ground clearance for patient hoist access



Pushing handles

four ergonomically positioned pushing handles for supreme manoeuvrability

Gas assisted backlift

unique design, precision controlled, easy lift system for enhanced user and patient comfort



K8 pressure care mattress

manufactured from temperature-sensitive gel feel foam that moulds to the patient's body shape, relieving pressure by distributing the load as evenly as possible. Outer material is anti-microbial, water resistant, vapour permeable and latex free

Infection control

smooth moulded surfaces and acrylic capped vac formings enclose trolley mechanics to minimise dirt traps. Anti-bacterial properties and innovative design for easy cleaning

Fixed transfusion pole

innovative quick release safety locking mechanism, integrates into either head or foot end of side rails for easy access and storage

Hydraulic lift mechanism

exceptional low height capability, adjusted by independently operating pedals on both sides of trolley



Castors

polyurethane tyres offer low rolling resistance for high manoeuvrability, 150mm castors fitted as standard, 200mm optional

Cylinder trough

side loading for ease of access, suitable for wide range of cylinder options including F, E or CD

Special bariatric version of this model also available – see page 10



Motorised **DRIVE** FEATURES

QA3
Patient Trolley

QA3 **DRIVE**
Patient Trolley

QA3
Powered Patient Trolley

QA3 **DRIVE**
Powered Patient Trolley

Inbuilt motorised drive offers effortless movement combined with ultimate control.

Because people and therefore patients are getting larger, it's crucial that we take moving and handling issues into account, giving practitioners a trolley on which patients can be moved and positioned as easily as possible.

The introduction of our new touch-activated, motorised DRIVE feature offers a major enhancement in a trolley that already has ease of use, practicality and patient comfort built in.

The trolley can also be used in traditional fifth wheel steer mode.



DRIVE handles

innovative touch sensitive design: simply press against the pop-up or fixed yellow pushing handles, and the trolley will move forward; pull back on them, and it will reverse; let go and it will stop



Effortless travel up to gradients of **10°**



Inbuilt motorised drive

no need to push or pull the trolley: our new, inbuilt motorised DRIVE feature linked to the trolley's 5th wheel, offers controlled, effortless travel up to gradients of 10°

Long-life battery – 22 kilometers on a single charge

DRIVE feature powered by advanced nickel-metal hydride rechargeable battery



Highly accurate battery charge indicator – rapid charge



DESIGN & INNOVATION



MADE IN THE UK



GLOBAL DISTRIBUTION

Motorised DRIVE: effortless travel, ultimate control

Powered ⚡ FEATURES

QA3
Patient Trolley

QA3 // DRIVE
Patient Trolley

QA3
Powered ⚡ Patient Trolley

QA3 // DRIVE
Powered ⚡ Patient Trolley

Minimise risks for practitioners dealing with increasing patient weights with powered positioning: the whole trolley platform or the backrest can be raised or lowered electronically from the panel at the foot end.

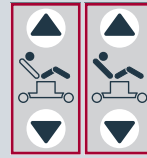

An additional powered feature places the trolley into the KneeFlex position for easy elevation of the lower limbs for patients having leg and foot procedures – position also provides additional comfort, particularly for patients undergoing abdominal procedures.

There's also a special CPR feature: return the trolley swiftly to a horizontal, optimal height position for CPR treatment.



Electrically Powered Functions

easy to operate using the positive feel push button controls on a panel at the foot of the trolley

Manual override systems as standard

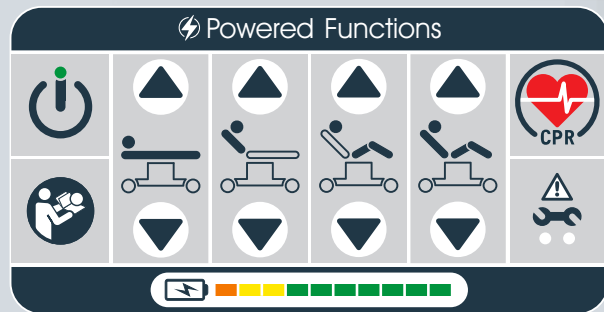

Platform height – electrically powered raise and lower mechanism

Offers smooth movement to position the trolley at any point in its height range – 475mm to 775mm (excluding mattress)

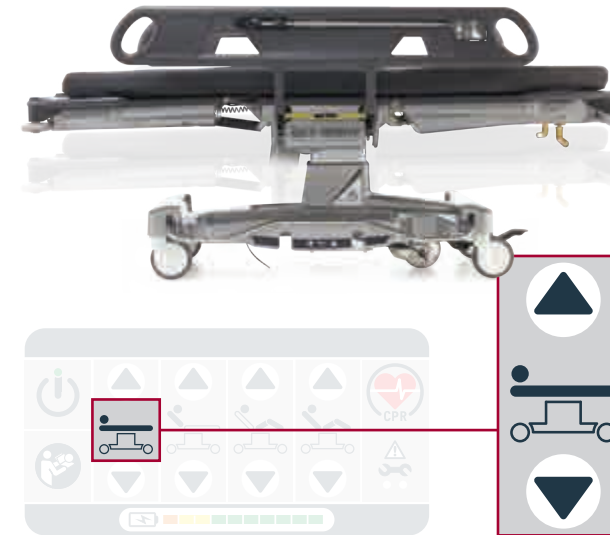

Backrest – electrically powered raise and lower mechanism

Positions the backrest anywhere between the vertical and horizontal for maximum patient comfort

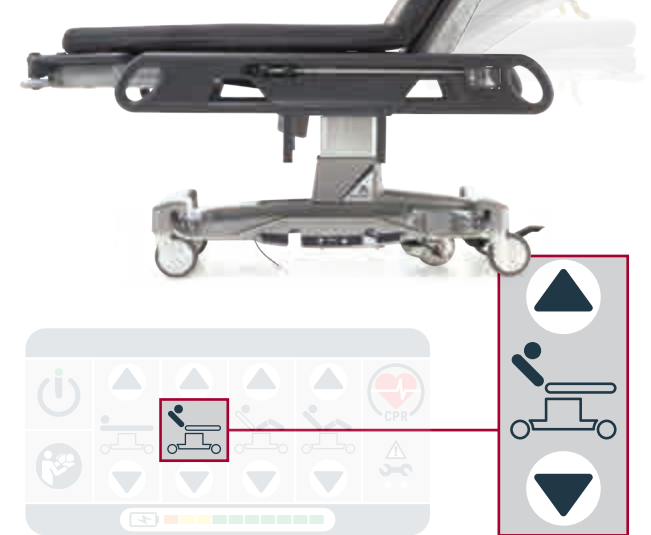

Lights on the power panel illuminate to refer the user to the manual if the equipment is being used incorrectly or to indicate when maintenance is required

If a patient needs CPR treatment, there is no time to lose: the powered CPR feature returns the trolley swiftly to a horizontal, optimal height position for CPR treatment

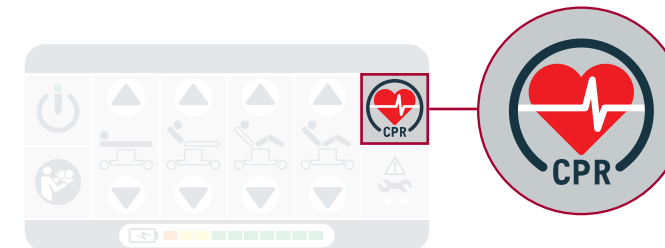

Trendelenburg – hydraulically powered tilt mechanism

Extremely smooth and controlled movement, even at the trolley's lowest height



Special features for a trolley that's more powerful, by design



BUILD OPTIONS

QA3 <800> for Bariatric Patients

Increased platform/mattress – width: 800mm

Again recognising the trend for increasing patient weights and sizes, we offer special Bariatric versions of the QA3.

The extra wide (800mm) platform significantly increases the surface area for added safety and comfort for Bariatric patients.



Increased surface area

Pressure care mattress

320kg weight capacity

As with all of our trolleys, the QA3 <800> is fitted with a K8 pressure care mattress.

Specially developed for this Bariatric trolley, the mattress core is made of high density foam, moulded with a unique castellated surface. This increases air flow within the mattress and helps to relieve pressure by distributing the patient's weight as evenly as possible across the surface area – particularly important for heavier patients.

Like other K8 models, the foam has antibacterial and microbial fungistatic properties and its latex-free, 4-way stretch polyurethane (PU) outer cover allows the skin to breathe – for greater patient comfort.

Finally, our unique ultrasonic sealing system effectively welds the seams of the outer cover material together to give an almost unbreakable seal, making the K8 a class leader in infection control.

 All models of the QA3 Patient Trolley have a weight capacity of 320kg and can be fitted with this increased platform width

Description	Code
QA3 Build Option <800>	22160
800mm Extended Width Patient Platform	

QA3
Patient Trolley



21191

QA3 // // // DRIVE
Patient Trolley

QA3
Powered Patient Trolley

QA3 // // // DRIVE
Powered Patient Trolley



21159



21175

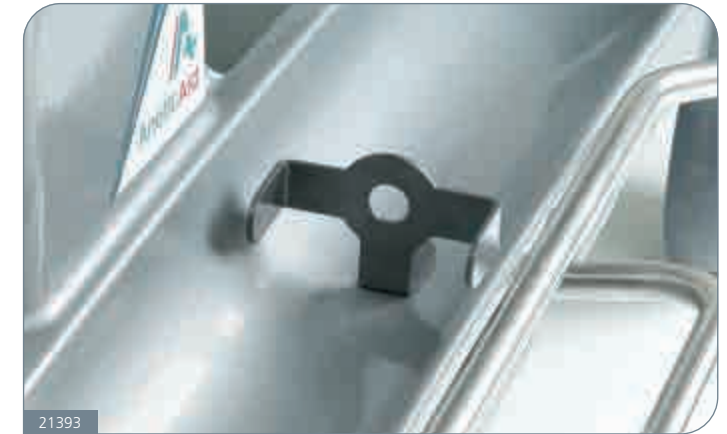

21393



21175-C1



21175-C2

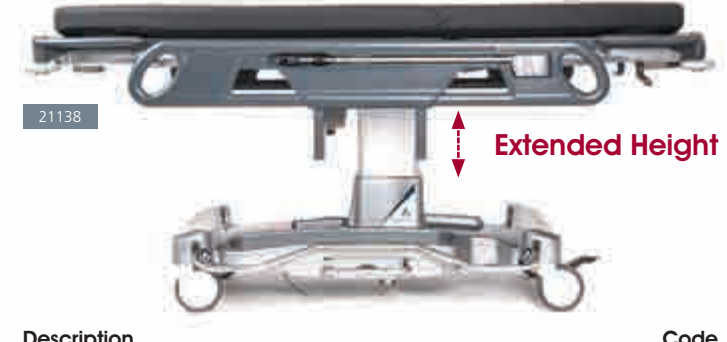

21138

Extended Height



21175-C3



21175-C4

Description	Code
200mm Castors	21132
Reverse Trendelenburg QA3/QA4M	21135
Increased Maximum Height 100mm	21138
Transfusion Poles x2 for Monitor Shelf	21152-B1
QA3 / QA4 Paper Roll Holder (up to 620mm wide) Universal	21159
Additional Transfusion Pole, Fixed	21161
Department Identification	21175
Colour ID Labelling – RED	22175-C1
Colour ID Labelling – BLUE	22175-C2
Colour ID Labelling – GREEN	22175-C3
Colour ID Labelling – YELLOW	22175-C4
Patient's Storage Container	21191
Oxygen Cylinder Bracket for CD Systems c/w Backing Plate	21393



Specialist build options available

ACCESSORIES

K8 Pressure Care Mattresses

Pressure care and infection control are top priorities in a trolley mattress – and Anetic Aid's independently tested K8 pressure care mattress addresses both of these vital factors.

At its core is high density foam, uniquely specified by Anetic Aid. This means that the mattress can be thinner, while still offering the same, if not better, pressure distribution than a thicker, less sophisticated foam. This is particularly important with tables and trolleys, as it means the overall height can be kept as low as possible for easy access by frail or elderly patients.

A layer of thermally responsive gel-feel memory foam is then added, further relieving pressure by distributing the patient's weight as evenly as possible across the surface area – whatever their position.



K8
TECHNOLOGY

In the science of Kinetics, there are eight points of contact the human body makes when lying on a hard surface – hence K8.

Description	Code
QA3 K8 Pressure Care Mattress with Zip Cover	21186
QA3 K8 Pressure Care Mattress – Replacement Waterproof Zip Cover	21186-B1



Anetic Aid's K8 technology mattresses can be found in over 90% of NHS hospitals in the UK.

K8 Mattress Normal Mattress

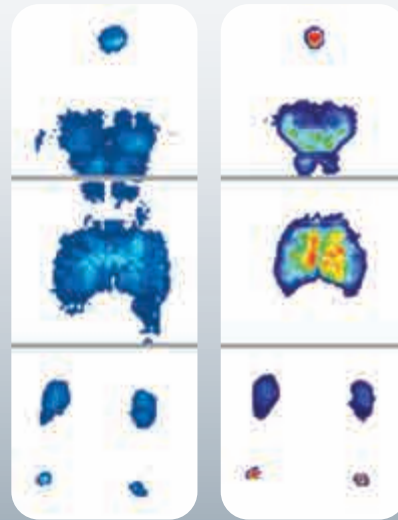

High risk pressure care mattress

Independently tested

Latex free

Antibacterial/vapour permeable

Welded seams

X-ray translucent

Infection control

Both of the foam elements of the mattress have antibacterial and microbial fungistatic properties – but Anetic Aid goes further, adding a latex-free, 4-way stretch polyurethane (PU) outer cover to each mattress (most materials being 2-way stretch), which is anti-microbial, water resistant and vapour permeable.

This means it is not only contamination-resistant, but it also allows the skin to breathe – for greater patient comfort.

Finally, a unique ultrasonic sealing system effectively welds the seams of the outer cover material together to give an almost unbreakable seal, making the K8 a class leader in infection control.

QA3
Patient Trolley

QA3 // // // DRIVE
Patient Trolley

QA3
Powered Patient Trolley

QA3 // // // DRIVE
Powered Patient Trolley

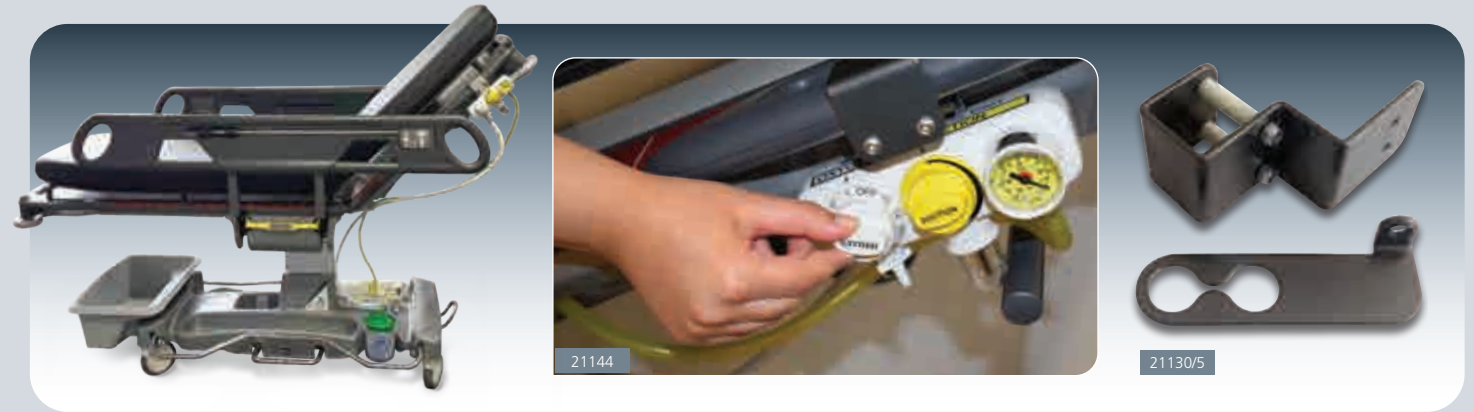

Description

Description	Code
QA3 Medirail Bracketry for SOS System	21130/5
Suction – Injector and Probe for CD and HX Cylinder (complete)	21143
Suction – SOS Unit c/w 90° O ₂ Connector	21144
Suction – Single Stage Medireg and Schrader – Bullnose O ₂	21144-A1

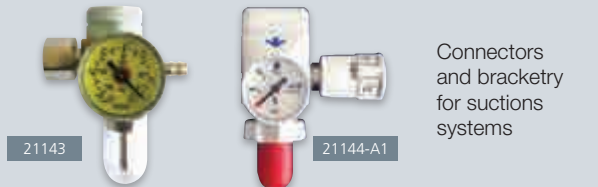

Additional products for all QA3 Trolley models

Specially designed and manufactured accessories for QA3 Patient and Emergency Trolley Systems.

Description	Code
Monitor Shelf c/w Removable Refreshment Tray	21152
Refreshment Tray ONLY	21152-A1
QA3 Foot-end Extension c/w 100mm Pad	21153
QA3 Side Rail, Endoscopy Height Extension Demi-frame	21165
QA3 Side Rail Covers, Grey (pair)	21172
QA3 Side Rail Covers, Child Print (pair)	21173
Theatre Pillow c/w QA3 Mattress Retention Strap	21188
QA3 and QA4 Trolley Systems Push / Pull Bar	21390

Wide range of extra items to complement any QA3 trolley





LIFETIME WARRANTY

Subject to annual servicing

QA3 Trolley System:
we offer the unique
and popular
'Lifetime Warranty Scheme'

Take out a service package for regular
maintenance costs, fixed for 10 years, including a
10 YEAR WARRANTY

Covers engineer's time and
most parts – also ask about our **AnetiCare**
maintenance programmes

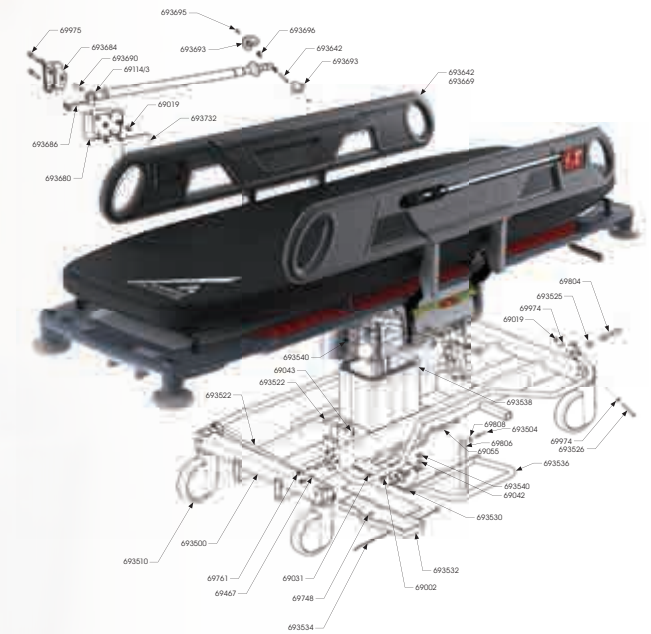

DESIGN & INNOVATION



MADE IN THE UK



GLOBAL DISTRIBUTION

Value for money: minimum downtime, maximum peace of mind



QA3

Patient Trolley

Specifications

Overall length:
2150mm

Overall width:
835mm (side rails up)
735mm (side rails down)

Height range excluding mattress:
475mm to 775mm

Trolley weight:
128kg (21110)
143.5kg (21112)
141kg (21116)
148kg (21114)

Maximum patient weight:
320kg (Please refer to user manual)

Please refer to 'Instructions for Use' for full product specification details

Standard features

Hydraulic lift mechanism – exceptional low height capability

Vertically operated side rails – giving a virtually zero transfer gap

Trendelenburg tilt – extremely smooth and controlled mechanism

Latest castor technology – low rolling resistance for high manoeuvrability

5th wheel steering – easily guided by one person

Pushing handles – ergonomically positioned

Gas assisted backlift – horizontal to near vertical

Advanced braking system – exceptionally stable platform

Fixed transfusion pole – innovative quick release

Cylinder trough – side loading

K8 pressure care mattress – body mould foam, anti-bacterial and latex free

Rotating buffers – at head and foot ends

Infection control – anti-bacterial properties and smooth moulded surfaces



For more information on any of our products or service contracts, call:

T +44 (0)1943 878647

sales@aneticaid.com

aneticaid.com

Innovative medical technology – practically applied

SPECIALISING IN:

Patient & Surgery Trolley Systems

Operation Table Accessories

Stainless Steel Theatre Furniture

Radiation Protection

Electro-Surgical Accessories

Tourniquet Systems

Fibre Optic Instruments

Service & Maintenance



MADE IN THE UK



AneticAid

Anetic Aid Ltd.

Sapper Jordan Rossi Business Park, Otley Road, Baildon BD17 7AX, UK